

Datasheet: 270KVA/50Hz - 325KVA/60Hz

G-Drive Marine

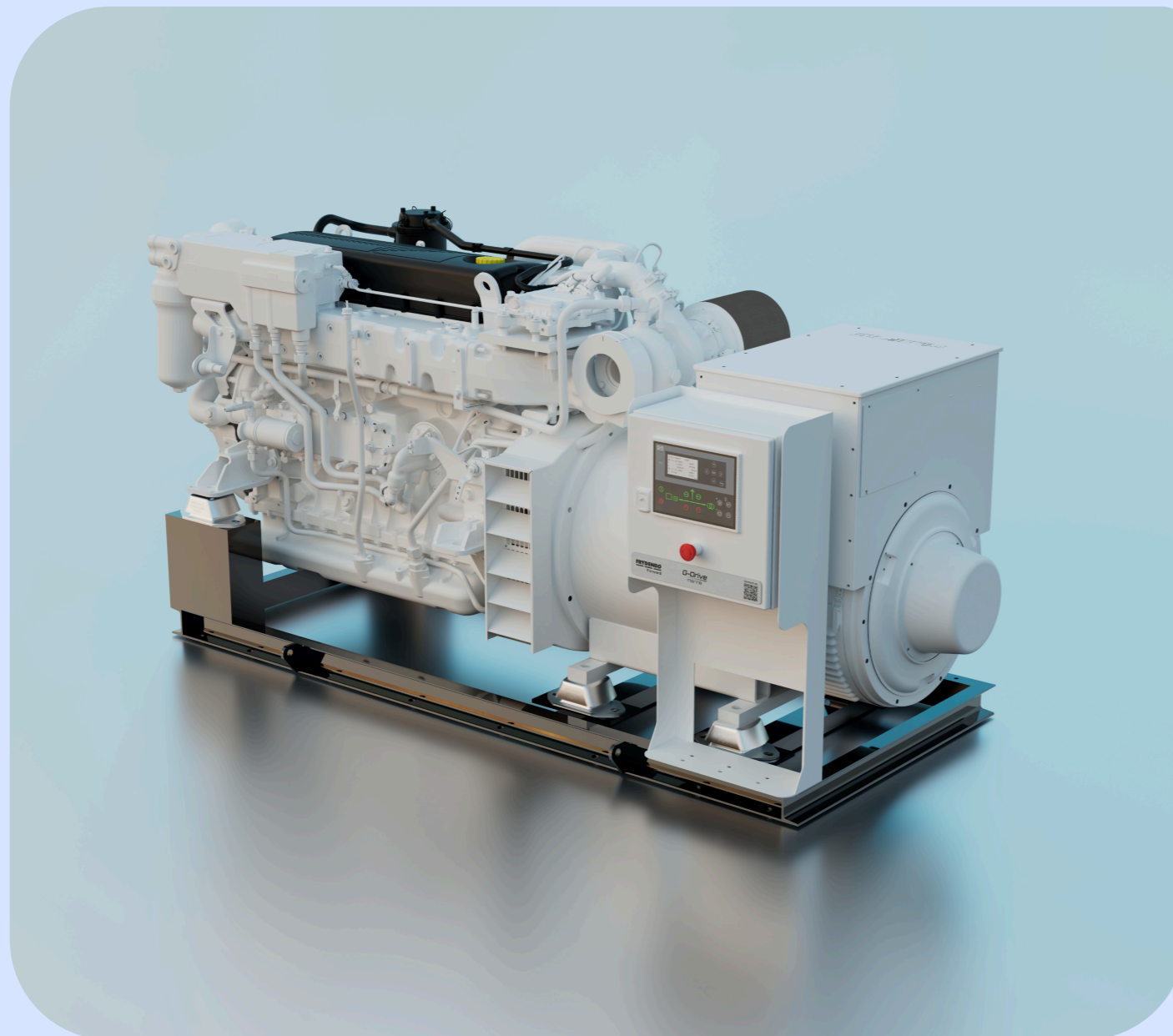

Engine – FPT C90 410

Generator – Stamford S4L1M-E41

Control system – Deif AGC 150 Marine



FFW 270.50M / 325.60M G-drive Marine

- A complete genset delivered on a common bedframe.
- Delivered according to customer requirement.
- Engine and generator with alarm and monitoring system.

Main Features

Frequency / RPM	HZ / RPM	50 / 1500	60 / 1800
Voltage	V	230/400	440
Prime rated power	KVA	*270 / 216	*325 / 260
Power factor	Cos Φ	0,8	0,8
Phace		3ph	3ph

*PRP Prime Power conforms to ISO 8528.Unlimited hours per year.
 Maximum mean load factor of 70% of rated power over 24 h of operation.
 Overload +10% (maximum of 1 h in 12 h, maximum in 25 h per year)

Type approval

- Engine are type approval by Rina.
- Generator type approval by all major classification societies.
- Controllsystem Deif AGC 150 marine type appoved by all major societies.
- The compleat genset can by delivered with classification certificate from factory on request.

Technical description:

- The compleat genset delivered on a common bedframe.
- Engine and generator directly linked together with SAE1 / 14 disc.
- FPT Engine C90 410, electronic common rail.
- Stamford S4L1M-E41 with MX341 Avr, PMG, dropp kit for parallell operation and heater (230V). Temp rise class F, Tropical insulation class H, thermostats for winding temperature.
- Monitoring; Deif AGC 150 engine marine drive cabinet on bedframe for non classified controllsystem. Ready for integration to vessel control and alarm system.
- IMO marpol tier II / tier III

Rating type

Maximum power (*)	KWm	230	276
At speed	Rpm	1500	1800
Minimum idling speed	Rpm	600	600
Oil consumption at max rating	(% of fuel cons.)	0,25%	0,25%
Fuel consumption at rated speed	g/kWh	204	203
Minimum starting temperature without auxiliaries	°C	-10°C	-10°C

*Net Power at flywheel according to ISO 8665, after 50 hours running, Fuel diesel EN 590. Power tolerance 5

Dimensions

Length	(L) mm	2047 mm
Width	(W) mm	1095 mm
Height	(H) mm	1120 mm
Dry weight	Kg	2106 mm

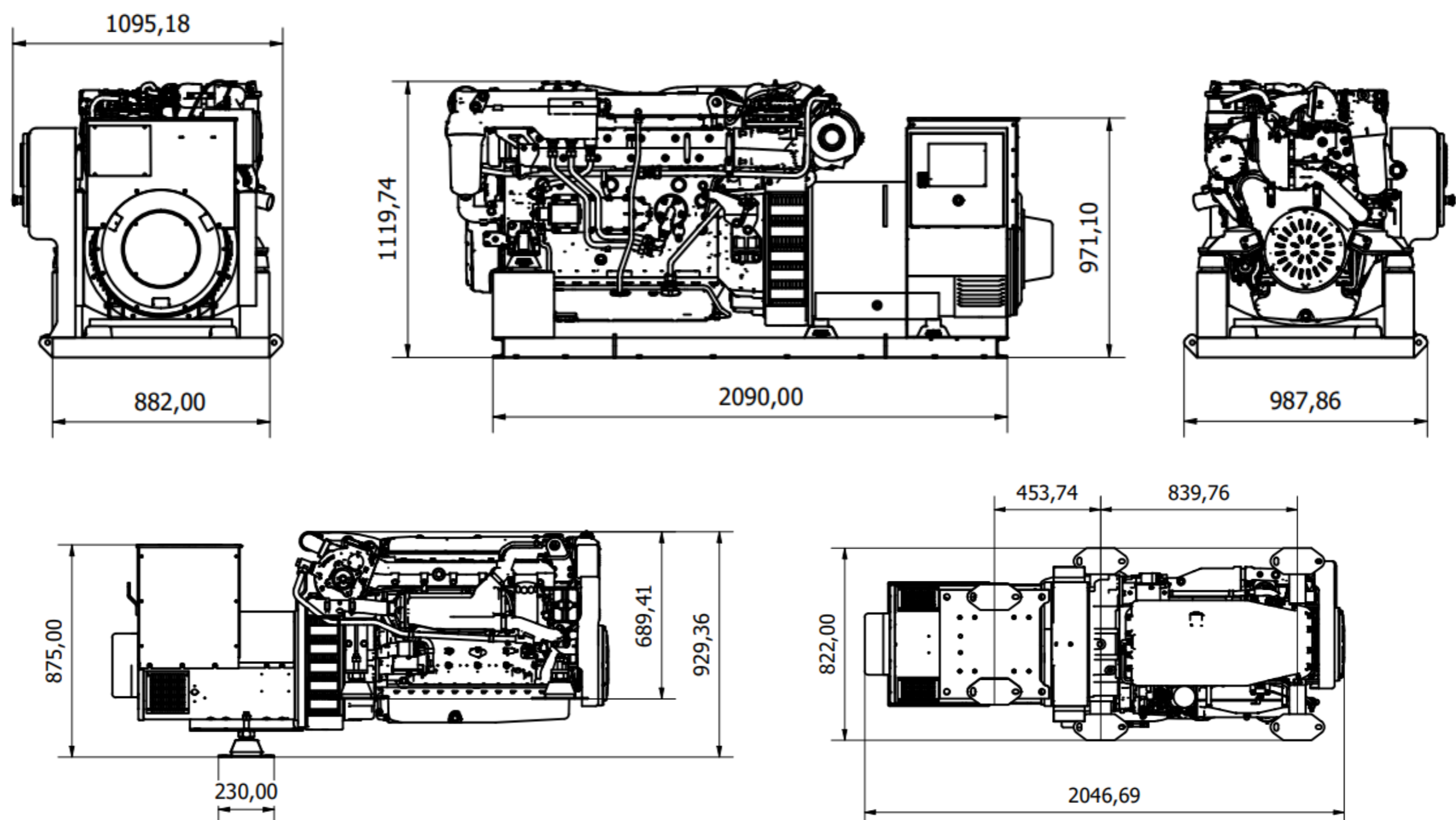

Kontakt
 +47 55 34 91 00
 forward@frydenbo.no

Besøk
 Hanøytangen 116
 5310 Hauglandshella

Post
 Postboks 6164
 5892 BERGEN

EHF-890397832
 890397832@semine.no

5082 06 00646
 NO 890 397 832 MVA

Engine, specification and standard scope of delivery

Description	FPT IVECO
Engine model	C90 410
Cylinders arrangement	6 L
Total displacement	8,7 L
Valve per cylinder	4
Cooling system	Liquid
Engine management	EDC (Electronic Diesel Controller)
Injection system	CR
Water charge tank	Included
Fuel filter	1-right side
Fuel prefilter	Included (loose)
Fuel pump	1-gear driven
Oil filter	1-left side
Oil sump	Aluminium
Oil vapours blowby circuit	Included
Air filter	Rear side
Turbocharger	Waste gate (water cooled) Turbo with aftercooler (TCA)
Painting color	White "ICE"
Cooling type	HE - Heat exchanger tube type / Keel cooling
Engine stop device	ECU
Wiring harness	2 poles, isolated to ground
Voltage	24 VDC electrical starting with insulated poles
Flywheel housing / size	SAE 1 / 14"
RPM controll	ECU / Can-Bus

Generator, specification and standard scope of delivery

Type	Stamford S4LIM-E41
Control system	Seperately excited by PMG
AVR	MX 341
Protection	IP23
Insulation system	Class H
Winding / Rated power factor	311 / 0,8
Class - temp rise	Cont. F - 90/50°C
Flywheel housing / size	SAE 1 / 14"
Paralell operation	Droop kit included for paralell operation
Anti condensation heater	Included (230V)
Winding temperature	Termistors included
Type Approved (TA)	Dnv, BV, ABS, GL, Rina

Control system and specification, standard scope of delivery

Controller	Deif AGC 150 Marine (TA)
Speed controller	ECU
Local emergency stop	Included
Remote access	Ready for integration to vessel control and alarm system.
Analog and binary oil pressure	VDO
Analog and binary cooling water temperature sensor	VDO
Overspeed protection	Pick up unit to Deif AGC 150 Marine
Local reading of value	Actual cooling temp, oil pressure and rpm on local Deif AGC 150 Marine
Water charge tank	Low level alarm

Optional equipment.

Silencer	Dry without spark arrestor
Exhaust gas	Dry
Block heater	Water pre-heating coil 3000W, 230 volt
Winding and bearing temperature	PT 100 on request
Remote controller	Deif AGC 150 remote
Unmanned engine room(E0/UMS) According to Dnv rules for classification Pt.6 Ch2.Sec2 1.6.2	Danfoss transmitter and sensors with test valve and test pocket for periodic test. Safety shutdown unit according to rules of classification
Injection pipe	Double wall injection pipe with collection tank
Pipe protection	Protection oil and fuel pipings
SCR	SCR system according to IMO Tier III
Fuel filter	Double fuel filter in series
Oil filter	Double oil filter switchable dismantled from above
Other options	On request

Class society - Norwegian Maritime Authority (NMA)