

Datasheet: FFW 60.50M

60 KVA G-Drive Marine



Engine – FPT N67 150

Generator – Stamford UCM 224F1

Control system – Deif AGC 150 Marine



FFW 60.50M G-Drive Marine

- A complete genset delivered on a common bedframe.
- Engine and generator directly coupled together with SAE3 / 11,5 disc.
- Delivered according to customer requirement.
- Engine and generator with alarm and monitoring system on frame

Main Features

Frequency / RPM	HZ / RPM	50 / 1500
Voltage	V	230/400
*Prime rated power	KVA/ Kwe	*60 / 48
**Stand By Power	KVA /Kwe	**66 / 53
Power factor	Cos Φ	0,8
Phace		3ph

*PRP Prime rated power conforms to ISO 8528. Unlimited hours per year. Maximum mean load factor of 70% of rated power over 24h of operation.

**St.by +10% (maximum of 1 h in 12 h,maximum in 25 h per year).

Kontakt
 +47 55 34 91 00
 forward@frydenbo.no

Besøk
 Hanøytangen 116
 5310 Hauglandshella

Post
 Postboks 6164
 5892 BERGEN

EHF-890397832
 890397832@semine.no

5082 06 00646
 NO 890 397 832 MVA

Rating type

PRP

Maximum power (*)	KWm	54
At speed	Rpm	1500
Specific fuel consumption (rated speed)	g/kwh	228@1500
Oil consumption at max rating	% of fuel cons.	0,25%
Oil and oil filter maintenance interval for replacement	Houres	600

*Net Power at flywheel according to ISO 8665, after 50 hours running, Fuel Diesel EN 590. Power tolerance 5%.

Dimensions

Length	(L) mm	1518
Width	(W) mm	916 mm or 790 mm with generator panel not mounted on skid
Height	(H) mm	930 mm
Dry weight	Kg	967 kg

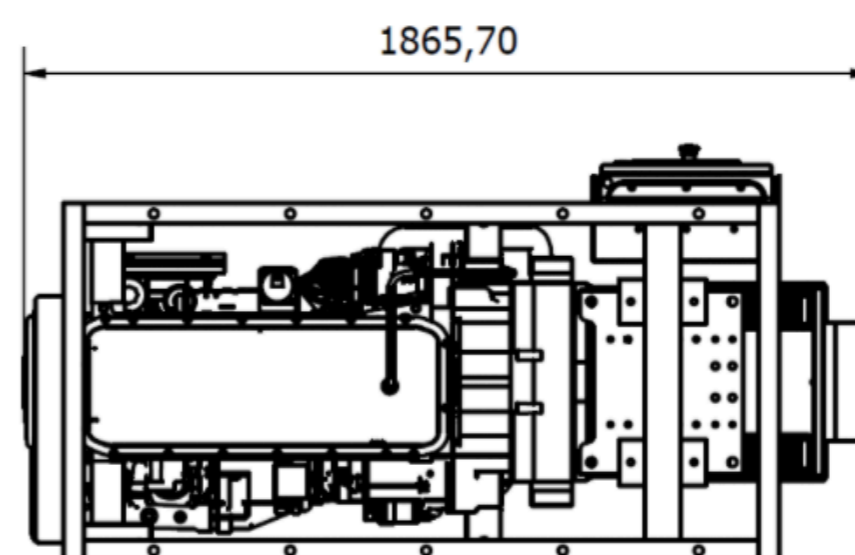
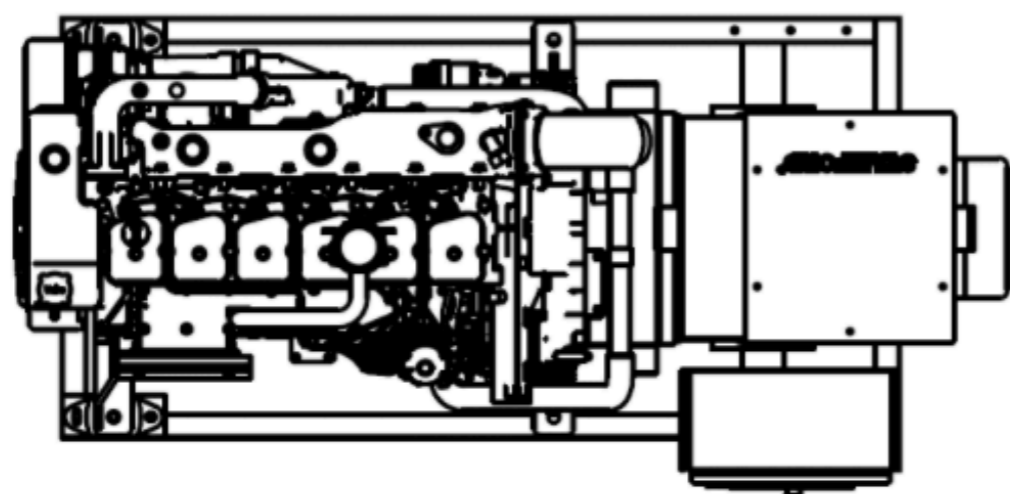
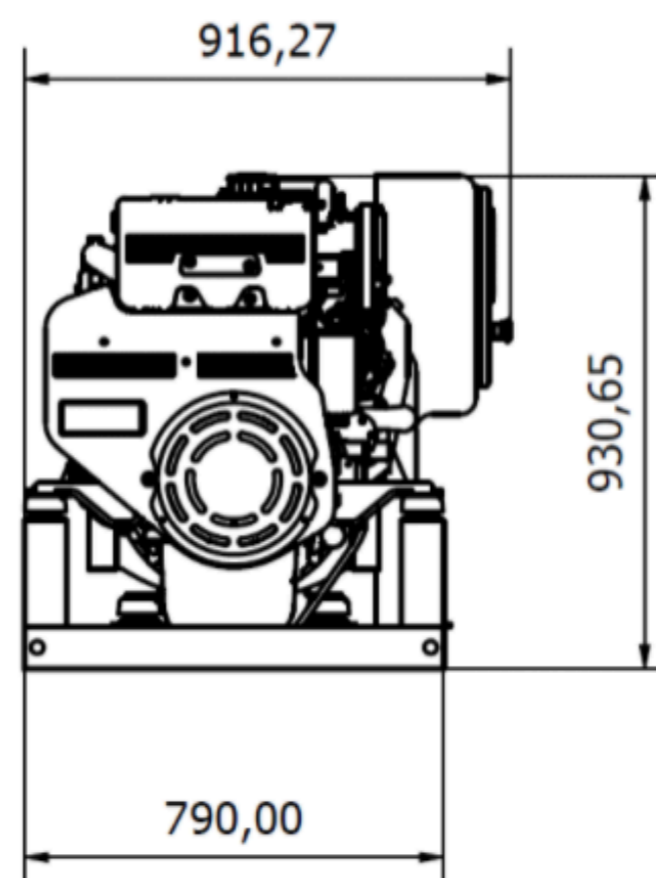
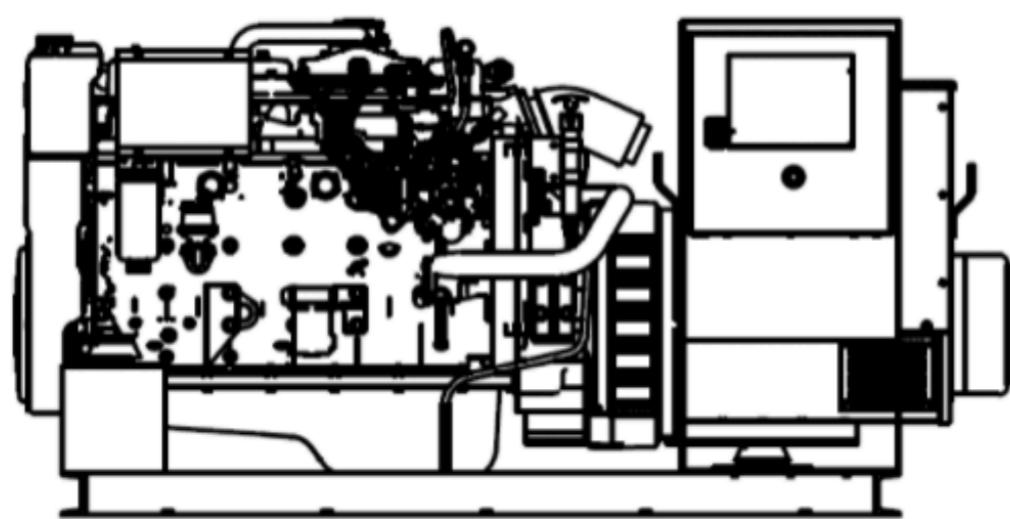

Kontakt
 +47 55 34 91 00
 forward@frydenbo.no

Besøk
 Hanøytangen 116
 5310 Hauglandshella

Post
 Postboks 6164
 5892 BERGEN

EHF-890397832
 890397832@semine.no

5082 06 00646
 NO 890 397 832 MVA

Engine, specification and standard scope of delivery

Description	FPT IVECO
Engine model	N67 MNAM 15.90
Cylinders arrangement	6 L
Total displacement	6.70 L
Valve per cylinder	2
Cooling system	Liquid
Engine management	Mechanical
Injection system	M
Water charge tank	Included
Fuel filter	1
Fuel prefilter	Included (loose)
Fuel pump	Injection pump calibration with pre-setting Kw 54 @ 1500 rpm
Oil filter	1
Oil sump	Sheet steel
Painting color	White "ICE"
Cooling type	HE - Heat exchanger tube type
Engine stop device	Electrical excitation (run coil)
Wiring harness	2 poles, isolated to ground
Voltage	24 VDC electrical starting with insulated poles
Flywheel housing / size	SAE 3 / 11"1/2
RPM controll	G.A.C 24 v electronic regulator, speed control unit ESD 5500
Tool kit	Iveco 4000
Homologation	IMO Marpol Tier 2, EU-IWV Stage IIIA

Generator, specification and standard scope of delivery

Type	Stamford UCM 224 F1
Control system	Separately excited by P.M.G
AVR	MX 343
Protection	IP23
Insulation system	Class H
Winding / Rated power factor	311 / 0,8
Class - temp rise	Cont. H - 110/50°C
Flywheel housing / size	SAE 3 / 11"1/2
Paralell operation	Droop kit included
Anti condensation heater	Included
Winding temperature	Thermistors
Type Approved (TA)	Dnv, BV, ABS, GL, Rina

Control system and specification, standard scope of delivery

Controller	Deif AGC 150 Marine (TA)
Speed controller	G.A.C. 24V electronic regulator. Speed control unit ESD 5500
Local emergency stop	Included
Remote access	Ready for integration to vessel control and alarm system
Analog and binary oil pressure	VDO
Analog and binary cooling water temperature sensor	VDO
Overspeed protection	Pick up unit to Deif AGC 150
Local reading of value	Actual cooling temp, oil pressure and rpm on local Deif AGC 150 controller

Optional equipment.

Injection pipe	Double wall injection pipe with collection tank
KC – cooling type	Keel cooled, ready for box cooler
Exhaust elbow	Dry, with integrated flexible compensator
Silencer	Dry without spark arrestor
Winding and bearing temperature	PT 100 on request
Remote controller	Deif AGC 150 remote
Block heater	Water pre-heating coil
Unmanned engine room (E0/UMS) According to Dnv rules for classification Pt.6 Ch2.Sec2 1.6.2	Danfoss transmitter and sensors with test valve and test pocket for periodic test. Safety shutdown unit according to rules of classification

Class society - Norwegian Maritime Authority (NMA)