

## Datasheet: FFW 88.50M

## 88 KVA G-Drive Marine

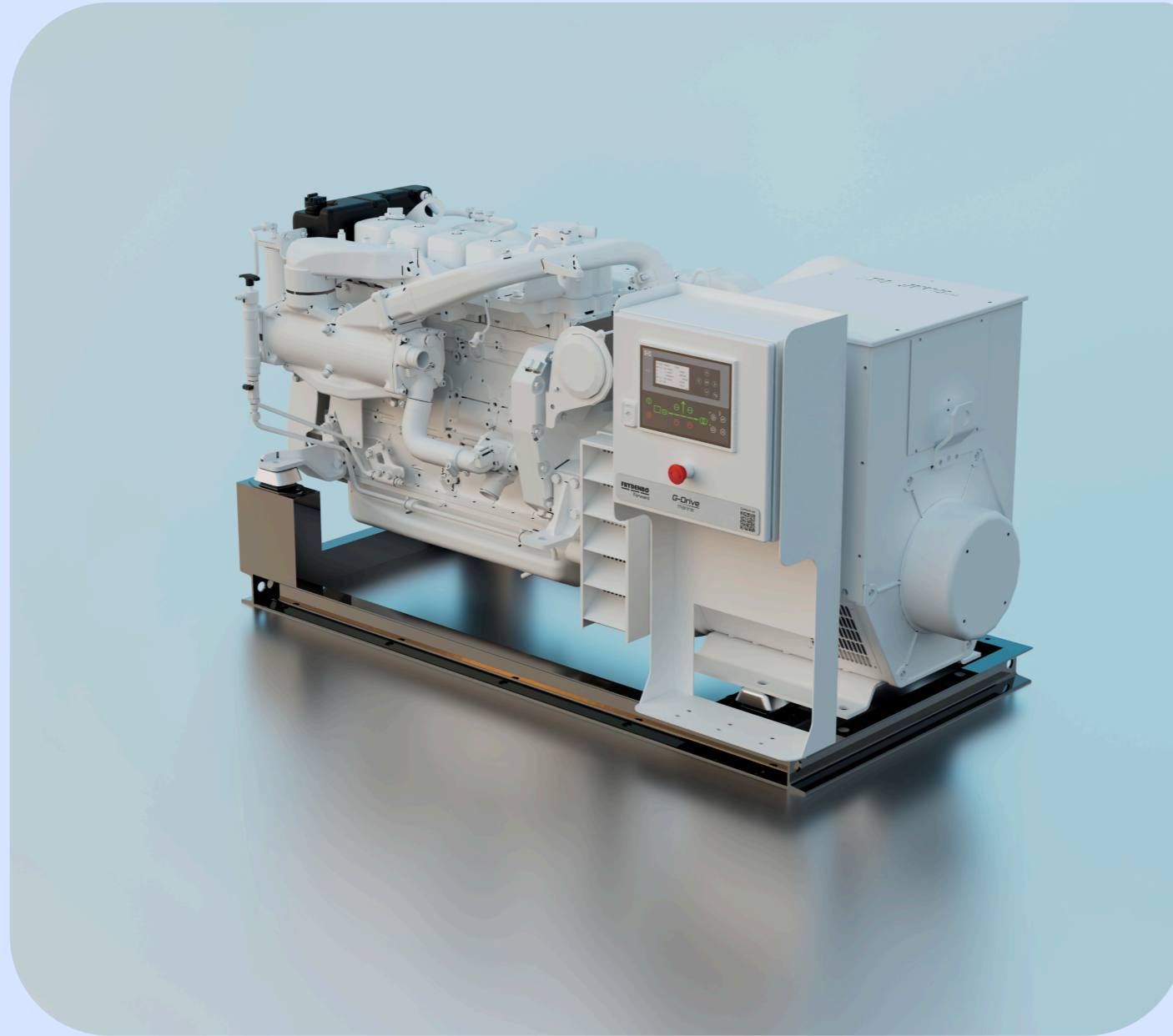

**Engine** – FPT N67MNAM28.90

**Generator** – Stamford UCM 274 D1

**Control system** – Deif AGC 150 Marine



### FFW 88.50M G-Drive Marine

- Complete genset delivered on a common bedframe.
- Engine and generator directly coupled together with SAE3 / 11,5 disc.
- Delivered according to customer requirement.
- Engine and generator with alarm and monitoring system on frame

### Main Features

Frequency / RPM	HZ / RPM	50 / 1500
Voltage	V	230/400
Prime rated power	KVA/ Kwe	*88 / 71
Stand By Power	KVA /Kwe	**97 / 78
Power factor	Cos $\Phi$	0,8
Phace		3ph

\*PRP Prime Power conforms to ISO 8528. Unlimited hours per year.  
 Maximum mean load factor of 70% of rated power over 24h of operation.  
 \*\*St.by +10% (maximum of 1 h in 12 h,maximum in 25 h per year).

**Kontakt**  
 +47 55 34 91 00  
 forward@frydenbo.no

**Besøk**  
 Hanøytangen 116  
 5310 Hauglandshella

**Post**  
 Postboks 6164  
 5892 BERGEN

EHF-890397832  
 890397832@semine.no

5082 06 00646  
 NO 890 397 832 MVA

## Rating type

**PRP**

Maximum power (*)	KWm	78
At speed	Rpm	1500
Specific fuel consumption (rated speed )	g/kwh	213@1500
Oil consumption at max rating	% of fuel cons.	0,25%
Oil and oil filter maintenance interval for replacement	Hours	600

\*Net Power at flywheel according to ISO 8665, after 50 hours running, Fuel Diesel EN 590. Power tolerance 5%.

## Dimensions

Length	(L) mm	1867 mm
Width	(W) mm	975 mm with generator panel mounted on skid, 814 mm without
Height	(H) mm	930 mm
Dry weight	Kg	993 kg

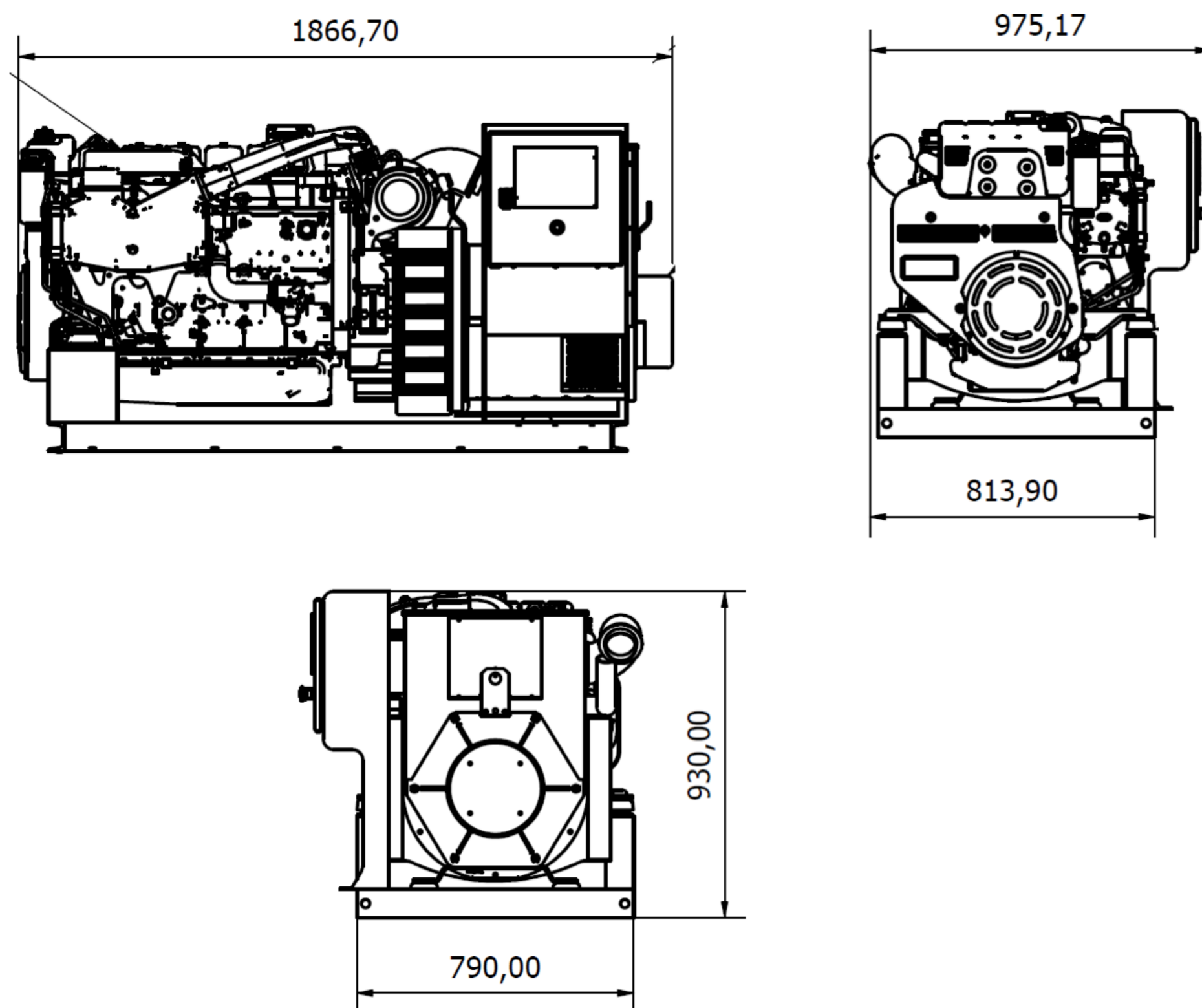

**Kontakt**  
 +47 55 34 91 00  
 forward@frydenbo.no

**Besøk**  
 Hanøytangen 116  
 5310 Hauglandshella

**Post**  
 Postboks 6164  
 5892 BERGEN

EHF-890397832  
 890397832@semine.no

5082 06 00646  
 NO 890 397 832 MVA

### Engine, specification and standard scope of delivery

Description	FPT IVECO
Engine model	N67 MNAM 28.90
Cylinders arrangement	6 L
Total displacement	6.70 L
Valve per cylinder	2
Cooling system	Liquid
Engine management	Mechanical
Injection system	M
Water charge tank	Included
Fuel filter	1
Fuel prefilter	Included ( loose )
Fuel pump	Fuelpump with pre-setting kw 78 @ 1800
Oil filter	1
Oil sump	Sheet steel
Painting color	White "ICE"
Cooling type	HE - Heat exchanger tube type
Engine stop device	Electrical excitation ( run coil )
Wiring harness	2 poles, isolated to ground
Voltage	24 VDC electrical starting with insulated poles
Flywheel housing / size	SAE 3 / 11"1/2
RPM controll	G.A.C 24 v electronic regulator, speed control unit ESD 5500
Tool kit	Iveco 4000
Homologation	IMO Marpol Tier 2, EU-IWV Stage IIIA

### Generator, specification and standard scope of delivery

Type	Stamford UCM 274 D1
Control system	Separately excited by P.M.G
AVR	MX 343
Protection	IP23
Insulation system	Class H
Winding / Rated power factor	311 / 0,8
Class - temp rise	Cont. H - 110/50°C
Flywheel housing / size	SAE 3 / 11"1/2
Paralell operation	Droop kit included
Anti condensation heater	Included
Winding temperature	Thermistors
Type Approved (TA )	Dnv, BV, ABS, GL, Rina

### Control system and specification, standard scope of delivery

Controller	Deif AGC 150 Marine ( TA )
Speed controller	G.A.C. 24V electronic regulator. Speed control unit ESD 5500
Local emergency stop	Included
Remote access	Ready for intigration to vessel controll and alarm system
Analog and binary oil pressure	VDO
Analog and binary cooling water temperature sensor	VDO
Overspeed protection	Pick up unit to Deif AGC 150
Local reading of value	Actual cooling temp, oil pressure and RPM on local Deif AGC 150 marine controller

### Optional equipment.

Injection pipe	Double wall injection pipe with collection tank
KC – cooling type	Keel cooled, ready for box cooler
Exhaust elbow	Dry, with integrated flexible compensator
Silencer	Dry without spark arrestor
Winding and bearing temperature	PT 100 on request
Remote controller	Deif AGC 150 remote
Block heater	Water pre-heating coil
Unmanned engine room( E0/UMS ) According to Dnv rules for classification Pt.6 Ch2.Sec2 1.6.2	Danfoss transmitter and sensors with test valve and test pocket for periodic test. Safety shutdown unit according to rules of classification

Class society - Norwegian Maritime Authority (NMA)